

# GearBoss® II

GearBoss II is a high-density storage solution designed to make equipment and storage rooms more efficient, organized, sanitary and accessible. With an innovative system of tracks, rolling carts and accessories the system can economize the square footage of storage areas by at least half when compared to traditional shelving or cabinetry. GearBoss units are designed to encourage airflow and organization. The modular system features accessories specific for the needs of bulky equipment like helmets and shoulder pads. Grille side closures and floor locks can provide a measure of security. GearBoss II Carts have a ten-year warranty.

## Intended Use

- GearBoss II is intended for indoor use in normal ambient temperature and humidity conditions - components must not be exposed to prolonged outside weather conditions.
- Heavy duty v-groove metal wheels follow the track keeping carts aligned and in place
- Ideal for maximizing cubic storage capacity, saving space and improving organization and access in athletic equipment rooms or any storage area.

## Specifications

- Each cart includes a grille top-shelf with integrated garment bar, one adjustable shelf and one section of floor track (additional shelves, bars, track and accessories sold separate)
- The carts provide for ventilation and unrestricted airflow
- The storage system and accessories are rugged and damage resistant with an expected fifteen-year life cycle
- The rail system is comprised of 14-gauge galvanized steel tracks bolt-mounted on top of existing floor
- Storage units run on low-friction v-grooved metal wheels with sealed lubricated bearings
- The storage carts are 72.7"w x 79"h x 32.5"d (1847 mm x 2007 mm x 826 mm)
- The cart chassis is manufactured from 14-gauge welded steel and finished with a black powder-coat paint
- The top shelf and garment bar assembly is constructed of 3/16" and 5/16" steel wire grille, 2 load-supporting 12-gauge formed channels and a 16-gauge 1-1/2" steel garment bar and finished in black powder-coat paint
- The end panels are constructed from 16-gauge 1-1/2" diameter steel tube frame filled with 3/16" and 5/16" steel wire grille with 3" (76 mm) grid spacing and finished with silver powder-coat paint
- Adjustable shelf is constructed of 3/16" and 5/16" steel wire grille, two load-supporting 12-gauge formed channels and finished in black powder-coat paint
- Top shelf and adjustable shelf load capacity is 150 lb (68 kg) each evenly distributed  
Total cart load capacity is 500 lb (227 kg)
- GearBoss II provides modularity capable of on-site re-configuration or future relocation
- Approximate weight: 205 lb (93 kg)
- Shipped ready-to-assemble with detailed instructions;  
Assembly takes approximately 15 minutes per cart with two people
- Product number 241A054

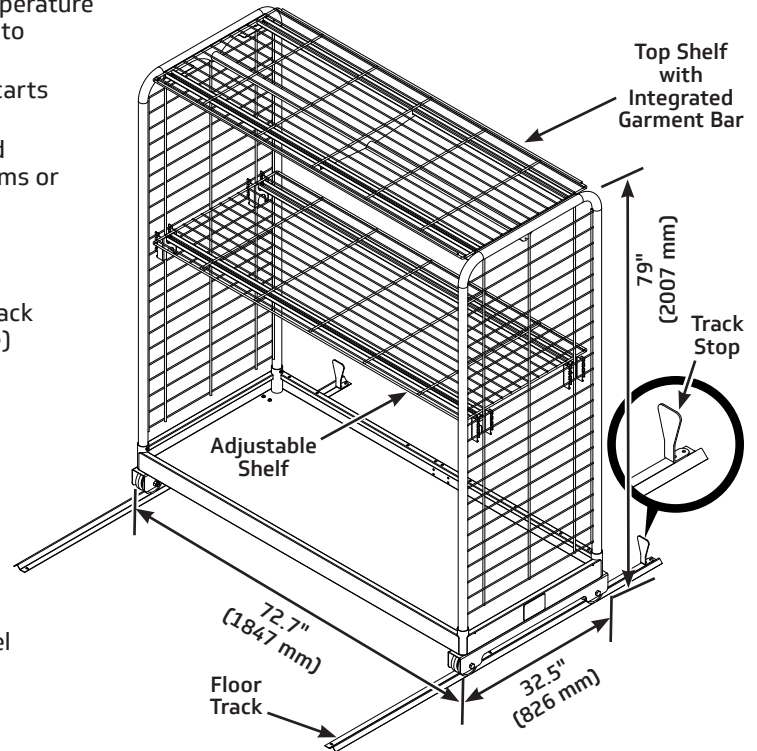

## Accessories

- Additional adjustable shelves
- Adjustable 12-gauge 1-1/2" diameter steel garment bars finished in black powder-coat paint
- Side security grid is constructed of 14-gauge formed metal brackets, 3/16" and 5/16" steel wire grilles and finished with black powder-coat paint
- Floor lock assembly holds carts together and is locked with a customer-provided lock for added security
- Track stop

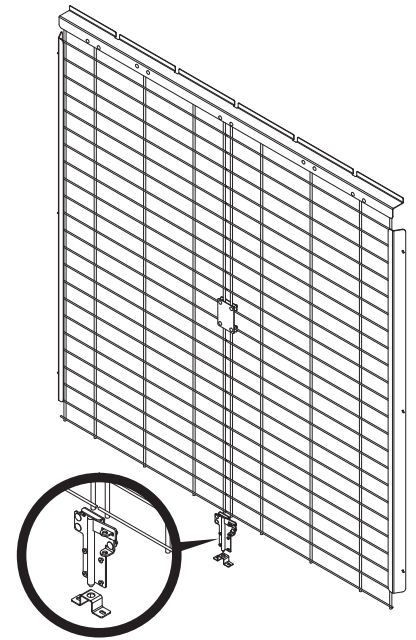

**Side Security Grid with Floor Lock**

**Wenger**

**JRCLANCY**

**GEARBOSS**

© 2024 Wenger Corporation  
USA/2024-03

**Minnesota Location**

Wenger Phone 800.4WENGER (493-6437) Wenger Worldwide +1.507.455.4100 | Parts & Service 800.887.7145 | wengercorp.com

GearBoss Phone 800.493.6437 | gearboss.com

555 Park Drive, PO Box 448 | Owatonna | MN 55060

**New York Location**

J.R. Clancy Phone 800.836.1885 JR Clancy Worldwide +1.315.451.3440 | jrclancy.com | 7041 Interstate Island Road | Syracuse | NY 13209